

QuickTime™ and a
decompressor
are needed to see this picture.

IPv6 EYOD Experiments

Danny McPherson danny@arbor.net

Randy Bush randy@psg.com

Goal of Experiments

- Eat our own dog food
- Is IPv6 practically usable?
- What improvements need to be made to make it practically usable?
- NANOG, APRICOT & IETF all recently conducted experiments to sample and foster usability
- AFNOG, RIPE, ARIN, ... experimenting as well
- Goals more educational and documentary than demonstrative

The Enterprise Usage Model

- Consumers depends on ISPs, many models there
- Enterprises likely to be first ones who can NOT obtain new or additional IPv4 address space
- Enterprises are more “controlled” environments
- They’re Randy’s customers :-)

So what is it like to be an
Enterprise that can only get
IPv6 space?

QuickTime™ and a
decompressor
are needed to see this picture.

A Pure IPv6 Network Today...

- Would not get access to >99.9% of the 'net
- So you could see the dancing kame turtle (<http://www.kame.net>) and bouncing Google logo (<http://ipv6.google.com>)

QuickTime™ and a
decompressor
are needed to see this picture.

- But not much else....
- Mainly because of **bits on the wire incompatibilities** with IPv4 and IPv6

A Pragmatic IPv6 LAN Today

- An IPv6-only network with NAT-PT at the border and totd
- Now we can get to the IPv6 world AND the IPv4 Internet
- See the kame, bouncing 'Google' and see native Yahoo!
- This should work for UNIX, Linux, Mac, Vista, ...

NANOG/APRICOT IPv6 Network

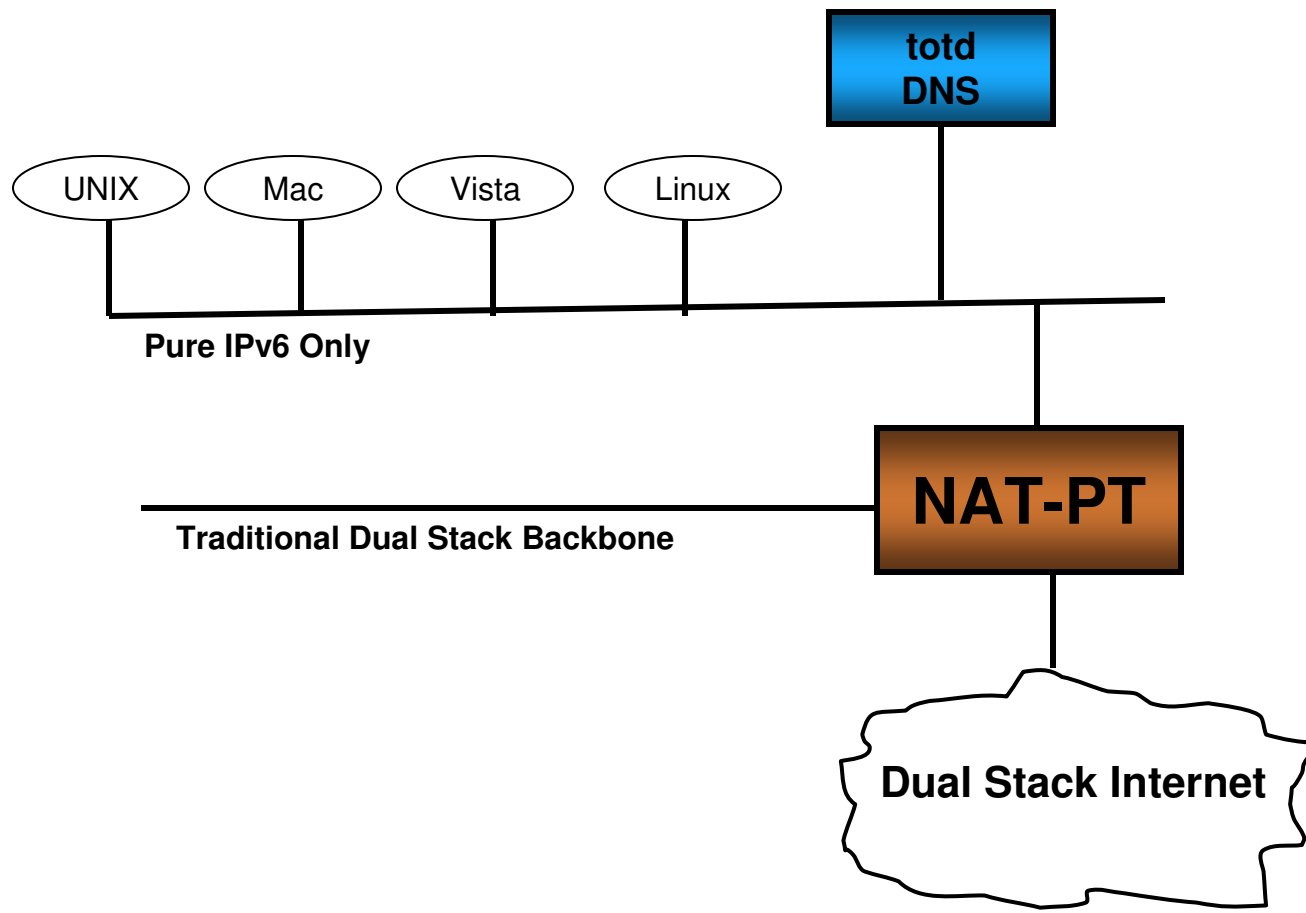

NAT-PT

- IPv6-only inside, dual-stack IPv4 and IPv6 on the other
- Stateful translation of TCP when no IP addresses are embedded
- ALGs needed for FTP, RTP, ... where addresses are embedded - e.g., layer violations occur - custom apps, etc..

The DNS Hack

- On a pure IPv6 network, if I get an A (DNS RR records that maps to an IPv4 address) record, what do I do?
- Panic, you can't use an A record!
- So the local DNS cache has a hack, *totd*, which takes an A, embeds it within a hacked IPv6 prefix, and synthesizes an AAAA
- NAT-PT knows the hack prefix, and strips it back to IPv4 to dual-stack

QuickTime™ and a decompressor are needed to see this picture.

TOTD - DNS Translation Proxy

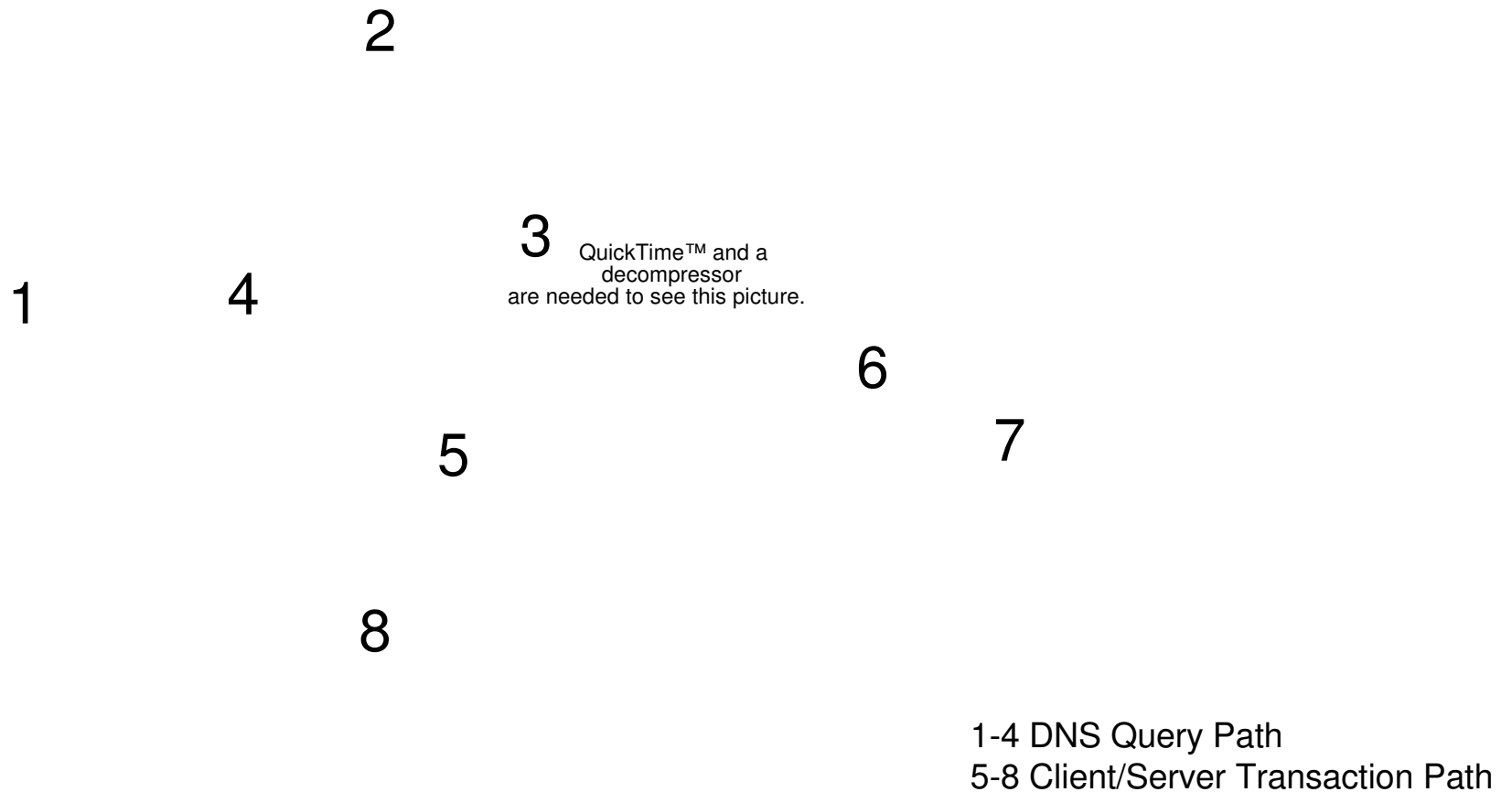

Diagram by Vasaka Visoottiviseth

<http://mucc.mahidol.ac.th/~ccvvs/totd-setup.html>

Windows XP

- XP can move payload over IPv6
- But does NOT do DNS over IPv6 transport (nor AD, or other things! “MSFT: Buy Vista”)
- So, the LAN has 1918 IPv4 space to carry DNS, but no exit for IPv4
- You get an IPv6 and IPv4 address, but should use the IPv6 for all real transport as IPv4 has no default
- You heard Tony, blame him :-)

Modified Network

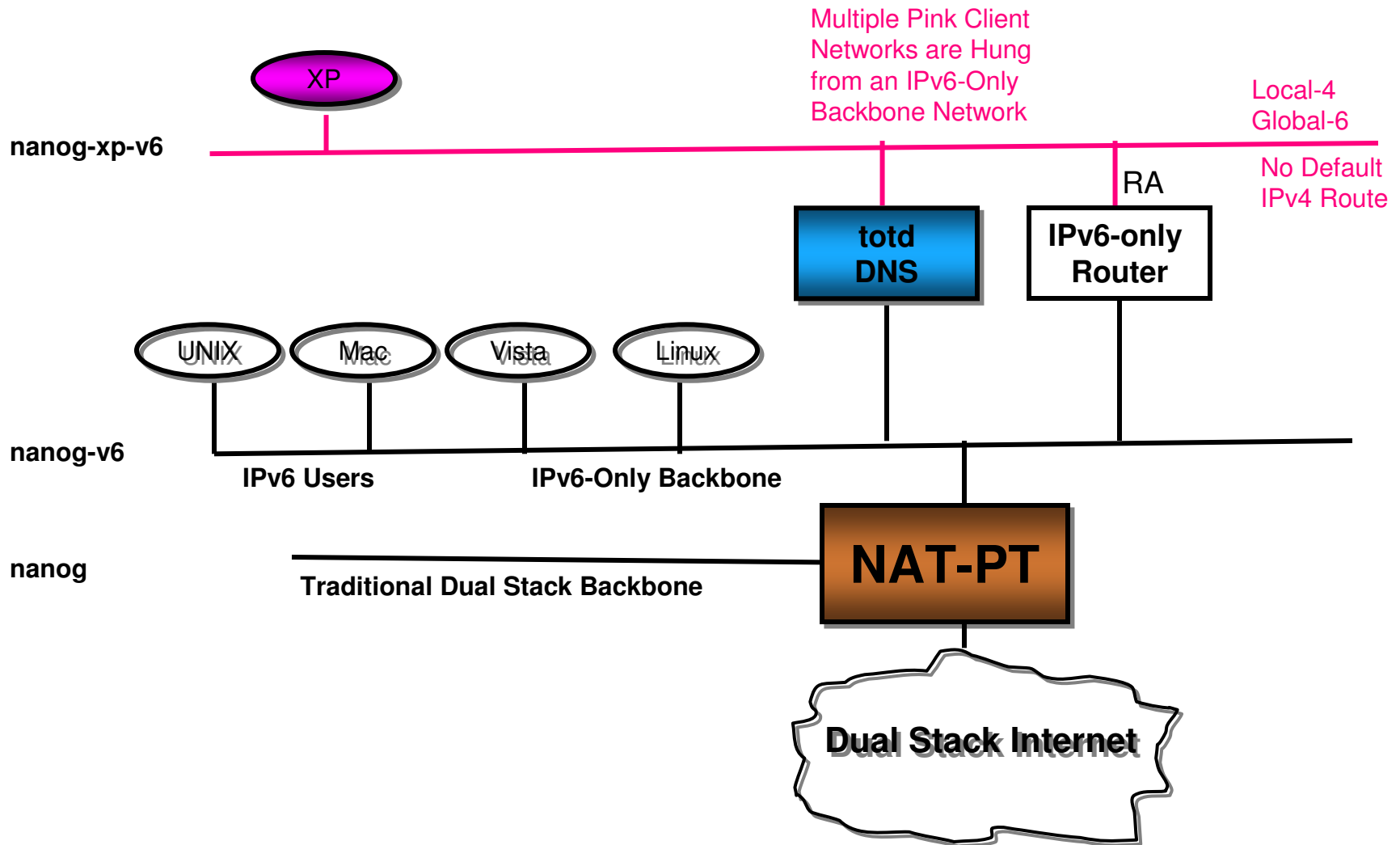

Access

- All SSIDs up from start
 - **nanog** normally fully dual-stack
 - **nanog-v6** with NAT-PT
 - **nanog-xp-v6** with 1918 DNS translation
- At APRICOT, for 90 minutes on Wednesday **apricot** went away, at NANOG for 60 minutes on Tuesday
- At NANOG some stats were gathered, none really collected at APRICOT

What We Learned

- 3/4 of users said they could not get on net but it was actually more like half
- Every component except UNIXes had bugs: NAT-PT, Vista, MacOS, XP, ...
- The prize to MacOS, which dropped capital 'A' from DNS server entry, among others
- We hope vendors now working to fix

NANOG MAC Address Stats

MAC address counts by VLAN at NANOG42; Data from Tuesday, Feb. 19 2008
(times corrected to PST)

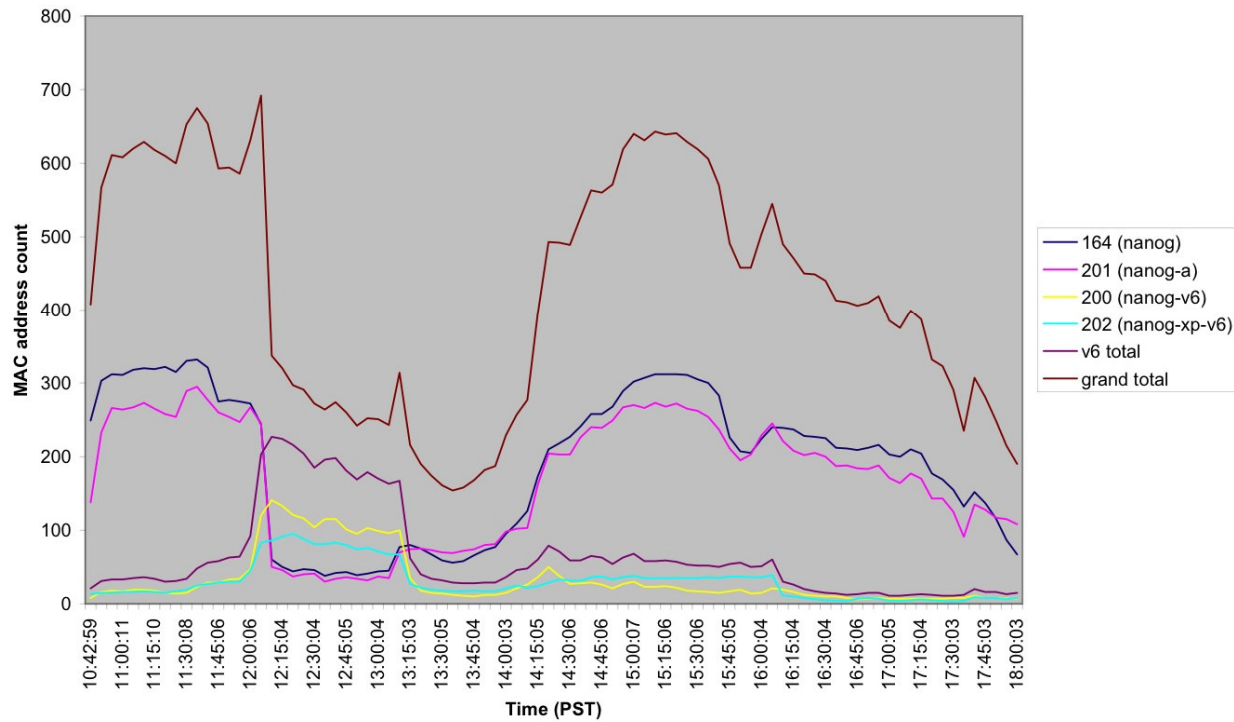

IETF 71 Experiment

- Held during IESG plenary session on Wednesday evening
- Already learned much from NANOG and APRICOT experiments
- No NAT-PT - would have been ironic considering recent move of NAT-PT specification to historic
- Dual-stack, v6-only, and 464-nat networks

Other IETF observations..

- Some observations..
 - No workie:
 - iTunes Store
 - Apple Bug Reporter
 - Skype
 - iPhone no IPv6 capabilities
 - Jabber (server issues with OpenFire per html v. txt transcripts, Adium client seemed OK - though many IM servers not reachable - e.g., google talk - though translators made available)
 - iChat will only work if there's still an IPv4 address on the system somewhere
 - www.ripe.net worked, but not others such as lirportal.ripe.net and ris.ripe.net
 - www.apple.com
 - jabber.psg.com had no AAAA records, although there is a www.psg.com one. Exists now :-)

IETF Experiment Notables

- There was a power outage just before the IPv6 outage - some speculate it was over IPv4...
- ipv6.google.com launched
 - Local stuff worked
 - Not much else
- Mark Andrews provided BIND fix for Windows XP to mitigate native DNS resolution issue (i.e., run local bind resolver)
- All IETF Web sites worked
- Made /. - “The Night the IETF Shut Off IPv4”
- /. not reachable via IPv6

Double NAT - v4v6v4

- Double NAT model to accommodate
- Described in
 - draft-durand-v6ops-natv4v6v4-01.txt
- Distributed NAT model where globally routed v4 addresses are shared among a pool of users
- MTU & ALG considerations
- Still very much research

How You Can Play

- <http://www.civil-tongue.net/6and4/>
- Has instructions for platforms
- Has instructions how to turn it back off when you go home!
- Is a wiki, so .. If you want to play:
 - Create a login ID, open a ticket and request editor privileges
 - You can also use tickets to report problems, send feedback, etc..
 - Share your experiences

Thanks To....

- Chung-Hwa Telecom, MERIT & Comcast
- Philip Smith, Lucy Lynch, Joel Jaeggli
- IJ & ISOC
- Cisco & Philip Smith
- APRICOT, NANOG & IETF Sponsors
- And Philip Smith...

Miscellany...

- NAT-PT is nasty, but with no bits on the wire compatibility, necessary
- Transition == co-existence for a long time
- Ubiquitous dual-stack no-opt at this stage
- End 2 end transparency will be further compromised, your packets will be more molested as a result
- IPv4 exhaustion is imminent, IPv6 deployment necessary

An Unanticipated Benefit...

- There has never existed a formally verifiable mechanism for authentication of address space allocations (i.e., IANA->RIR-LIR/ISP->)
- Because of concerns of IPv4 trading model, RIRs are developing model based on RPKI and SDR work
- Provides infrastructure for seeding IRR route objects, providing repository source for secure routing, either out of band, or down the road integrated into routing protocols (e.g., SoBGP or SBGP)

QuickTime™ and a
decompressor
are needed to see this picture.

EOF